

PZH CERTIFIED

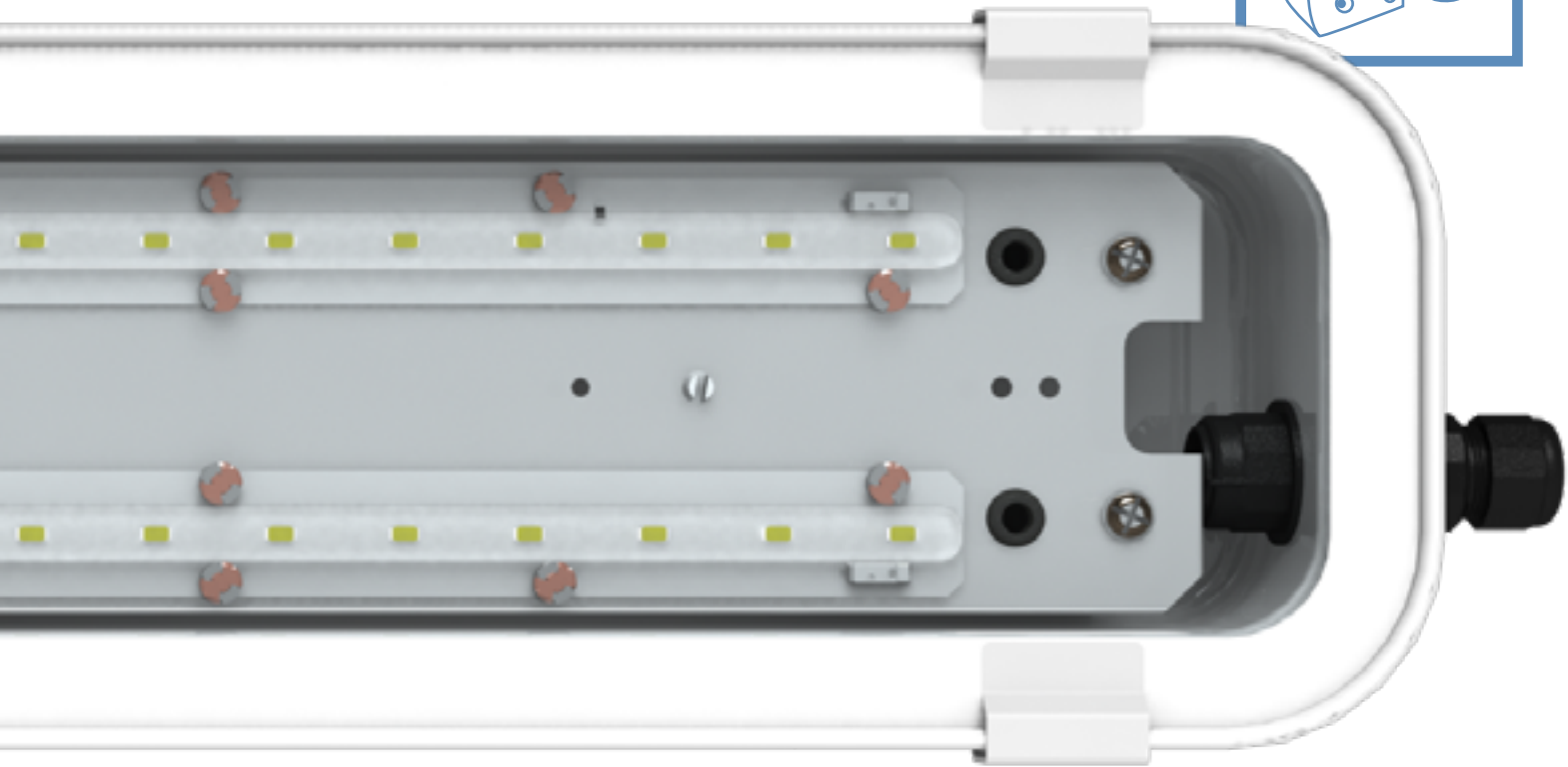

INS350LED





plug & 4get



FEATURES:



Chemical resistance
Encapsulated LED modules
SAFETY GLASS technology

CERTIFICATES AND APPROVALS:

PZH certified

COMMON APPLICATIONS



CHEMICAL PLANTS



CHEMICALS WAREHOUSES



PHARMACEUTICAL PLANTS



ANIMAL HUSBANDRY

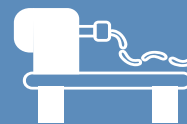

DELICATESSEN



DAIRY FACTORIES

Water and dustproof industrial light fixture with encapsulated LED modules designed for use in highly corrosive environments. Housing made of stainless steel with increased acid resistance, diffuser made of safety glass or PC. Easy and quick assembly that does not require interference inside the light fixture. Special anti-bacterial paint increases safety in food production

Light fixture has **PZH approval**. Light fixture can be made with DALI control system.

FEATURES

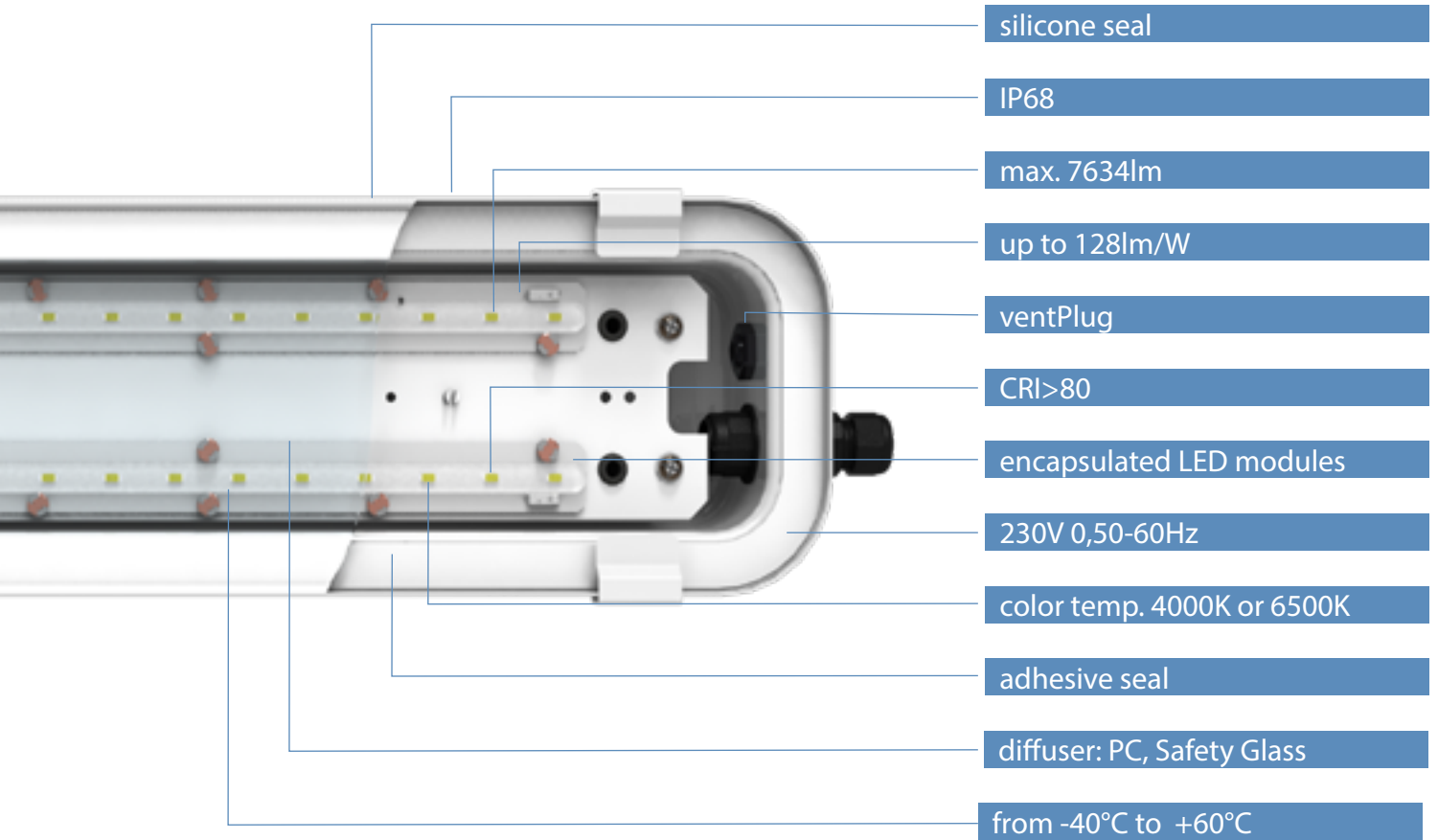

BRACKETS

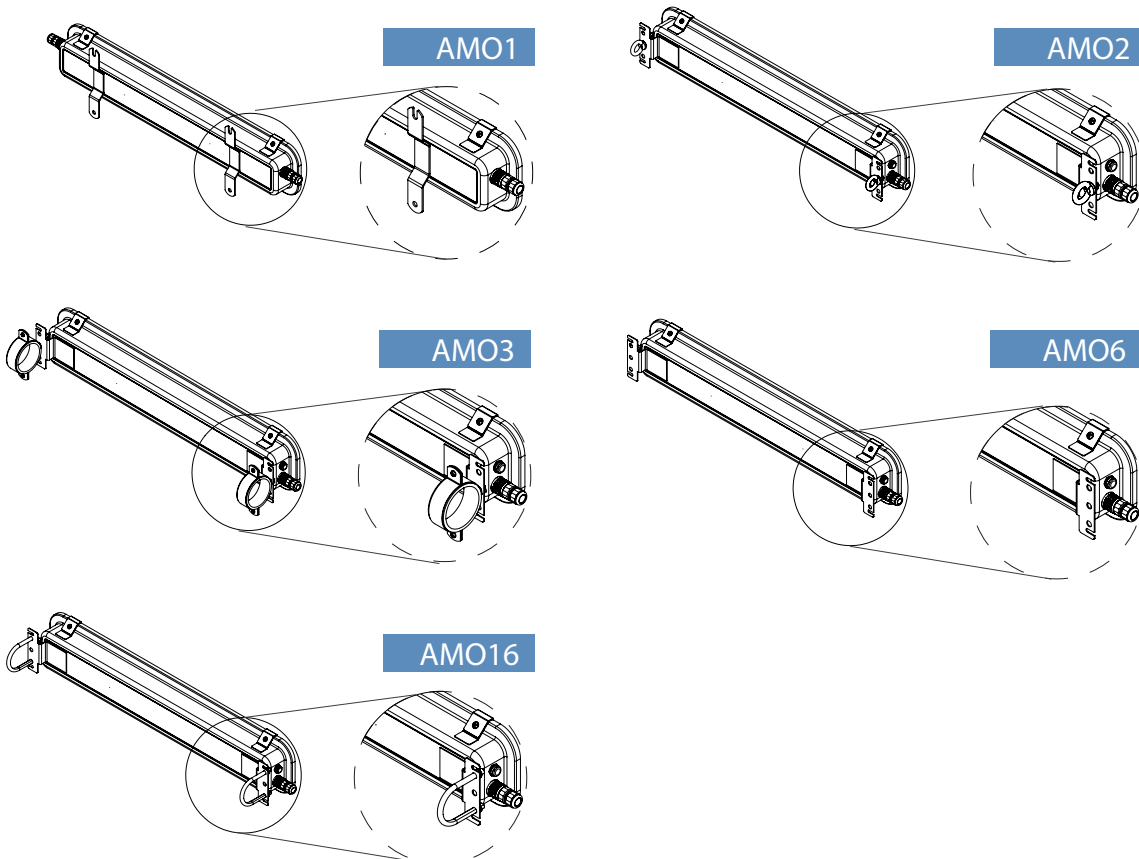

FEATURES

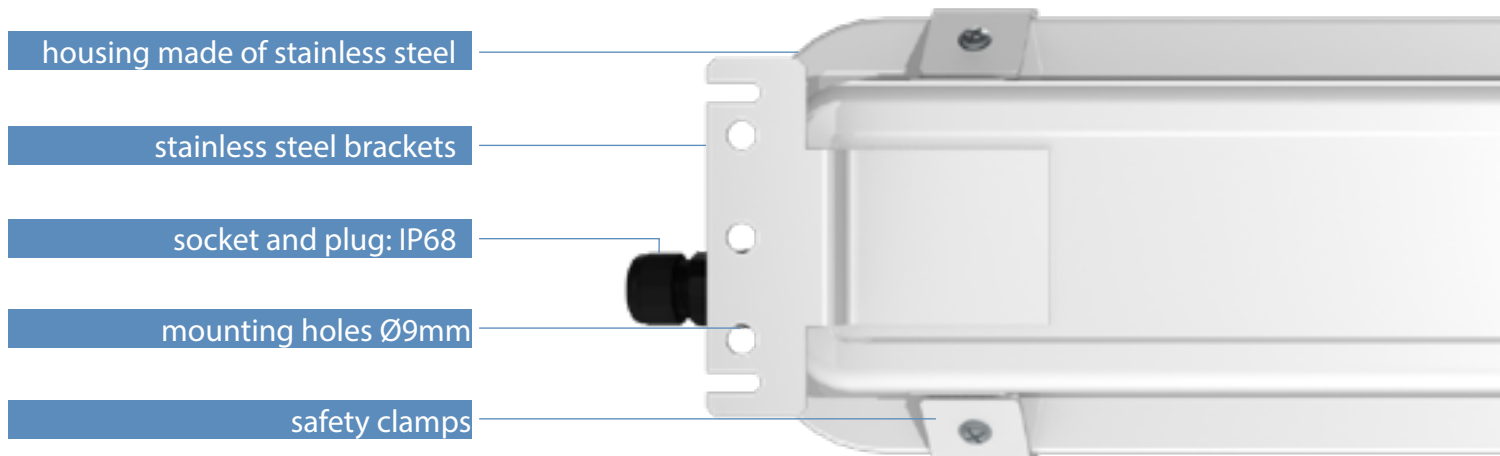

DIMENSIONS

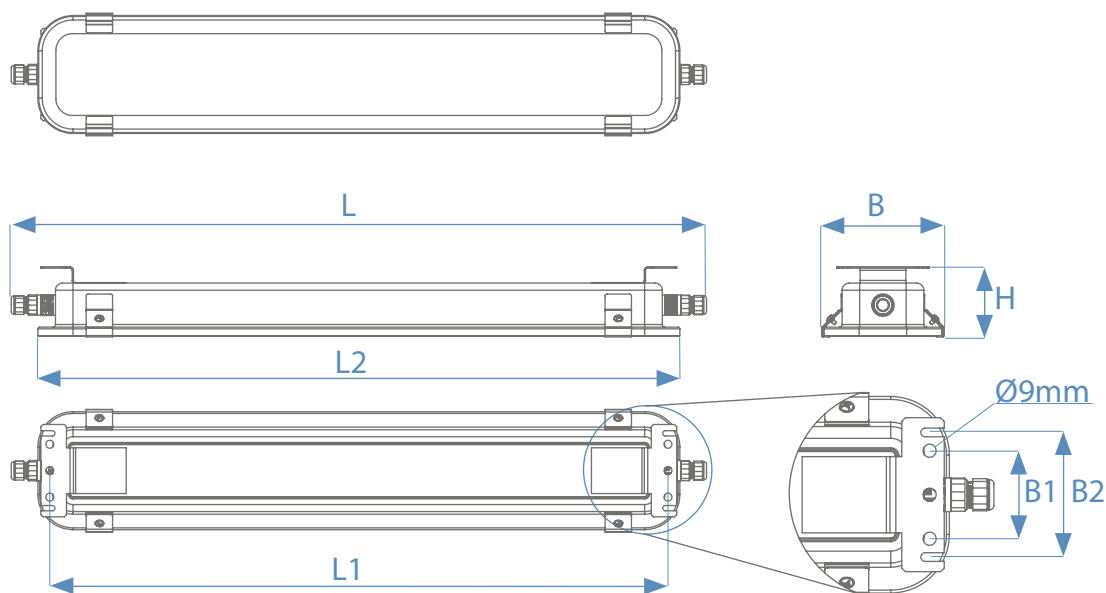

TYPE	L	L1	L2	H	B	B1	B2
INS350LED-0600	790	704	730	80	139	60	85
INS350LED-1200	1400	1314	1340	80	139	60	85

TYPES COMPARISON

TYPE	LUMINOUS FLUX [lm]	POWER CONSUMP. [W]	EFFICIENCY [lm/W]	AMBIENT TEMP.
INS350LED-0600-J2-1	2274	18,2	125	-25 -.- 60
INS350LED-0600-J2-3	3168	26,7	119	-25 -.- 50
INS350LED-1200-J4-1	4906	37,5	131	-40 -.- 60
INS350LED-1200-J4-3	6387	49,7	129	-40 -.- 60
INS350LED-1200-B4-1	7921	59,5	133	-40 -.- 40
INS350LED-0600-D2	2377	20,0	119	-40 -.- 60
INS350LED-1200-D4	4753	39,3	121	-40 -.- 60

SAVINGS COMPARISON

TYPE	SAVINGS*	SYSTEM SAVINGS 1:1**	REPLACEMENT T8
INS350LED-0600-J2-1	52%	57%	2x18
INS350LED-0600-J2-3	30%	55%	2x18
INS350LED-1200-J4-1	52%	55%	2x36
INS350LED-1200-J4-3	36%	54%	2x36
INS350LED-1200-B4-1	54%	59%	2x58
INS350LED-0600-D2	47%	55%	2x18
INS350LED-1200-D4	50%	51%	2x36

* power consumption savings of INS350LED light fitting compared to other producers standard T8 light fittings

** power consumption savings of INS350LED light fitting compared to other producers standard T8 light fittings, assuming basing on equal light flux of compared devices

PHOTOMETRY

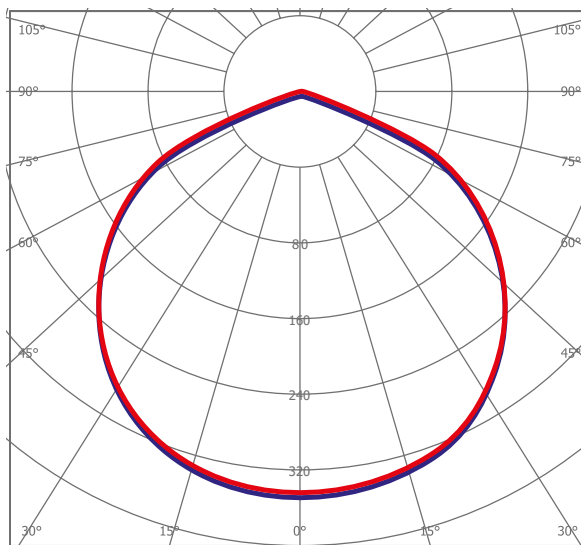
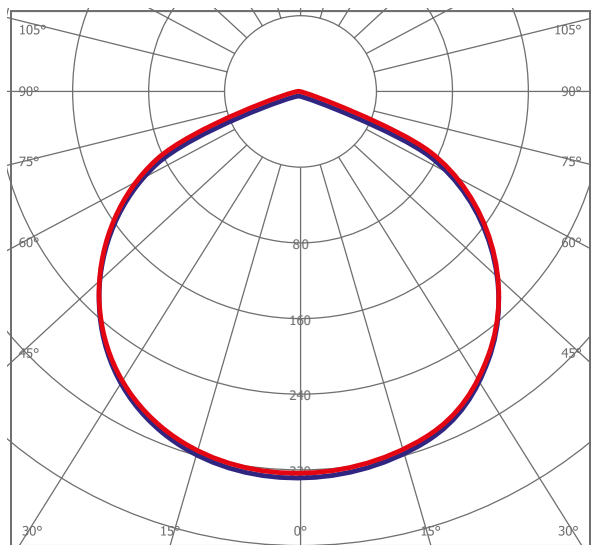

AVAILABLE CONFIGURATIONS

I	N	S	3	5	0	L	E	D	—					—				—	3	5	E	—			RST		—	NIRO	—			C4	—		
										0	6	0	0		J	2							30		10		20			SGL				DA	
										1	2	0	0		B	4							33		11		25		PC						
																							50												
																							55												
grupa group										przybliżona długość approximate length				typ modułu LED / LED module type		ilość /quantity	prąd sterowania driving current			zasilanie power supply		okablowanie wiring			wpusty kablowe cable inlets		materiał obudowy housing material		materiał klosza diffuser material		wersja specjalna special version		wersja awaryjna lub DALI emergency or DALI version		

PC - CLEAR type polycarbonate
SGL - laminated tempered glass

ADDITIONAL INFORMATIONS



Tempered laminated glass is a multi-layer safety glass that has greater resistance to heavy objects. The foil between the glass prevents the glass from spilling. Characteristic for tempered glass is the way of cracking after breaking into small pieces.



Version with plug&socket set, so it is not needed to open the fitting during installation. This solution allows fast assembly and simplifies further exploitation.

C4 - special version of the luminaire designed for use in an atmosphere of high corrosiveness. All external, metal elements of the light fitting are made of stainless steel. LED modules are made in a hermetic version, which ensures a long lifetime.



Optional DA version of the light fitting is equipped with an integrated power supply unit with DALI interface, which allows to control parameters of lighting - depending on data from motion sensors or BIM settings. Properly configured lighting control system can significantly reduce costs of energy and improve the ergonomics of users.

DOWNLOADS

